

Installation Manual

NU  **AQUA**

800GPD Tankless RO



For NU Aqua Product ID (SKU):

WU-800GPD-TL
WU-800GPD-ALK-TL
WU-800GPD-UV-TL
WU-800GPD-ALK-UV-TL

WU-600GPD-TL
(600GPD Versions)

Congratulations on Your New

Reverse Osmosis
System



**Scan here
for link to video**



Watch the complete
installation guide at

nuaquasystems.com/install

Table of contents

Introduction

Conditions	Page	4
Introduction	Page	5
System Requirements	Page	5

Preparation

Inspection	Page	6
Recommended tools	Page	6
Installation components	Page	6
Quick connect guide	Page	7
Tube cutting guide	Page	7

Installation

Feed water adapter	Page	8
Leak stop valve	Page	9
Drain saddle	Page	10
Faucet installation	Page	11
System installation	Page	12
Alkaline system installation	Page	13
UV system installation	Page	14-15
Alkaline & UV system installation	Page	16-17

System use and care

System startup	Page	18
Filter changes	Page	19
Trouble shooting	Page	20
Warranty	Page	21-22

Conditions



READ THIS FIRST

- Please pay attention to the following installation and safety recommendations:
- Read the installation manual before installing this system.

READ THIS FIRST

- Please pay attention to the following installation and safety recommendations
- Read the installation manual before installing this system.

INCOMING WATER

Incoming water pressure must be between 14.5 PSI and 58 PSI. If your water pressure is above 58 PSI you will need a pressure regulator for your system. Test your water pressure occasionally to make sure the system is performing. If your water is microbiologically unsafe or of unknown quality do not use this system without adequate disinfection before or after the system. Extremely hot or cold incoming water will damage the system and cannot be used. Do not install where water hammer conditions exist, you should install a water hammer arrestor.

LEAKS

The included leak stop valve must be installed. Inspect all connections after the installation to make sure no leaks occur, wait until after the system is pressurized (turned on) to inspect again. Check the system occasionally after installation or maintenance to make sure no leaks have developed. Install the system in a location with adequate drainage.

GENERAL

This RO system unit is for climate controlled indoor use only. Exposure to overly high or low temperature ranges will damage the unit. Follow all of your state and local laws and codes regarding plumbing even if they differ from what is stated in this manual. If your state law requires it or you prefer to, we recommend using a professional licensed installer or plumber who meets the requirements of this system. All O-Rings, fittings, tubing, filter canisters, and teflon tape wear out after a certain period of time. The lifetime of your components are subject to change with the quality of the water supplied. Use appropriate eye and face protection when performing any drilling.

MAINTENANCE

The owner/user is obligated to properly maintain the RO system when necessary. This includes the following:

- Always use NU Aqua Systems replacement filters in accordance to the filter change schedule.

At least every 3 years:

- Replace the tubing, and fittings.
- Replace the teflon tape on all threaded connections and fittings.

At least every 5 years:

- Replace the faucet.

LIMIT OF LIABILITY

In all circumstances, NU Aqua System's maximum liability is limited to the purchase price of the product(s) sold. NU Aqua Systems is not responsible or financially liable for any water damage, property damage, or personal injury, direct or indirect, that may occur from normal or correct use of the products we sell, catastrophic failure of the products we sell, failure to properly connect the units to water supply lines, and/or failure to understand and observe the proper water pressure ratings and requirements for these units. Use, install and monitor all of our products solely at your own risk. Always check all connections for leaks periodically. NU Aqua Systems is not responsible for any leaks or water damage. In case some states do not allow the exclusion or limitation of incidental or consequential damages, you may choose to return the system. If you choose to keep it, you insist this exclusion still applies to you.

Introduction

Thank you for your purchase of the NU Aqua reverse osmosis drinking water system. We're excited for you to experience the benefits of a premium home water filter system and hope that you are as well. This guide is intended to make your installation pain free and can be followed step by step with our installation video.

Scan Me!



**WANT YOUR FILTERS DELIVERED AUTOMATICALLY?
JOIN THE FILTER CLUB AND GET YOUR FILTERS AT A DISCOUNT.**

Stage	Description	Service life
	2 in 1 Carbon block & polypropylene filter SKU: WU-S1SCB-TL	3 - 6 Months
	Granular activated carbon filter SKU: WU-S2GAC-TL	6 - 12 Months
	800GPD Reverse osmosis membrane SKU: WU-S3800MB-TL	24 - 36 Months
	Optional: Alkaline filter SKU: WU-STG1-ALK-CT	8 - 12 Months
	Optional: Ultraviolet filter SKU: HC-UVC1140GPD	6 - 7 Years

System Requirements

System Operating Pressure: 14.5 - 58 PSI

Incoming Water Temperature: 40° - 100°F (5°-38°C)



Water Pressure Must Not Exceed 58PSI
Temperature must not exceed 100°F or go below 40°F
System is for indoor use only

Inspection

After unpacking your new RO system and all the components, we recommend that you thoroughly inspect all fittings and tubing to ensure nothing has come loose during shipping. If any part appears cracked or broken from shipping, do not proceed with installation and contact us directly.

Email: support@nuaquasystems.com

Phone: 1(888) 621-0460

Recommended Tools



Drill with a 1/4" and 5/8" drill bit



Open ended wrench



Phillips screwdriver



Razor blade



14 mm wrench

Installation Components



RO System



Filter Set



Power Supply



Faucet



Quick connector



Leak stop valve



Feed Water Adapter



1/4" Tubing



3/8" Tubing



Drain saddle



1/4" Retaining Clip



3/8" Retaining Clip

Optional Components



UV Filter Kit



Alkaline Filter Kit

Quick Connect Guide

Tubing/Fittings/ Plug Removal

If there is a retaining clip on the collet of the fitting it must be removed first. Push and hold the collet down to unlock the tubing and gently pull the tube/fitting/plug to remove it.

Install or Remove Retaining Clips

To lock a tube in it's fitting make sure that it is fully inserted. Slide the retaining clip between the collet and fitting. Before tubing can be removed from a fitting you must remove this clip first. To remove the retaining clip simply pull the clip away from the fitting until it slide completely out.

Insert Tubing

Push the tubing straight and level into the fitting. When inserting the tubing make sure you push until it stops to ensure the lock is activated. The tubing will travel 5/8" into the fitting. Gently pull on the tubing to check that the lock is activated.



NOTE:
Always check each connection
to make sure its secure

How to Cut Tubing

When cutting the supplied tubing its important to use a sharp razor blade. Place the tubing on a flat surface and cut straight through the tubing. All cuts to your tubing must be perfectly straight to ensure the best connections.



NOTE:
Improperly cut tubing may cause
a leak

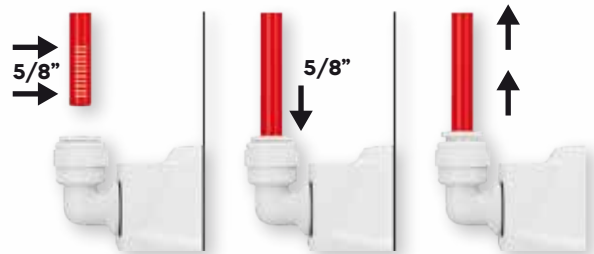
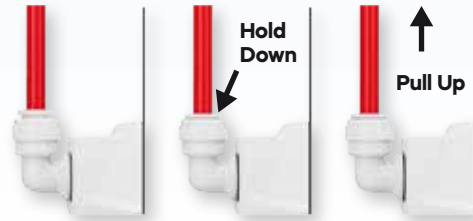
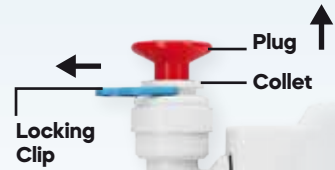

Installation

Feed Water Adapter

1. Locate and turn off the cold water valve under your sink. Next turn on the cold water faucet to drain any remaining water in the line.

2. Place a towel below your cold water valve to catch any remaining water in the line. Loosen the nut on the water line where it is attached to the valve. Feed water adapter can be installed in either location A or B as illustrated in the diagram.

3. Wrap the threads of the water valve and feed water adapter 8-10 times with teflon tape. Using an adjustable wrench secure the feed water adapter onto the cold water valve and the water line to the feed water adapter.

4. Turn the feed water valve to the off position for the remainder of the installation process.

5. Insert one end of your red tubing into the quick connect fitting on your feed water adapter. Secure in place with a retaining clip.



WARNINGS:

Only connect to cold water line.
Hot water will damage your system.



WARNINGS:

Turn the hot water valve off when installing on a single handed faucet.

1/2" Connection



3/8" Connection



Open



Closed



Installation

Leak Stop Valve Installation



WARNING:
Failure to install Leak Stop Valve will void Warranty



NOTE:
It may be best to insert the cartridge after the initial startup is complete

1. Locate the lowest point within your cabinet or installation location. Using the included screws, secure your leak stop valve in this location

2. Locate the 3/8" tubing coming from the feed water adapter and cut it near the location of the leak stopper. Connect the end of the tubing coming from the feed water adapter to the quick connect on the leak stop valve labeled "in".

3. Take off the plastic wrap off the leak cartridge and place it inside the leak stop valve as shown.

4. Turn the leak stop valve switch down to put it in the on position.



Installation

Drain Saddle



1. Locate a section on your drain plumbing using the image above and mark the location with a pen. If the drain saddle is to be installed on a horizontal section you must position the hole on top of the pipe.

2. Use a drill with a 1/4" drill bit on the section you marked. Be careful to drill only through one side of the pipe.

3. Remove the center of the foam pad included with the drain saddle. Peel off the adhesive tape on the back side and attach it to the drain saddle half with the quick connect fitting. Make sure the center hole aligns with the hole in the drain saddle.

4. Press the two nuts into the back of the drain saddle by hand.

5. Slide a small screwdriver through the quick connect fitting on the drain saddle half and through the hole drilled in your drain pipe. This will keep the holes aligned during the installation.

6. While holding the drain saddle in place secure the back half using the two supplied screws and a screwdriver. Tighten both screws till the drain saddle is secure. You may remove the screwdriver holding the drain saddle in place.

7. Locate your black tubing and insert one end into the quick connect fitting on your drain saddle.

Installation

Faucet Installation

Drilling

If your sink has an existing hole this can be used for your faucet. If you have to drill a new hole follow the steps below.

Granite / Marble / Quartz sinks

 **Keep the drill bit and hole wet during the drilling process**

1. Locate the section on your countertop to install your faucet. Using plumbers clay form a ring around the section you will be drilling. This will be used to retain water for the drilling process.

2. Fill the ring with water. Using a 5/8" diamond tip hole saw drill bit slowly begin drilling. Apply light, and even pressure and let the drill do the work.

Stainless Sink

1. Locate the section on your countertop to install your faucet and drill a 1/4" pilot hole. Once completely drilled through, switch to a 5/8" drill bit and re-drill the same hole.

Installation

1. Insert the faucet into the hole in your countertop.
2. Slide the rubber washer followed by the metal washer up the threaded shaft of the faucet and secure in place with the included nut.
3. Install the quick connect fitting to the threaded shaft and secure in place with a retaining clip.
4. Connect the 1/4" tubing into the quick connect fitting and secure in place with a retaining clip

Open and Closed Position

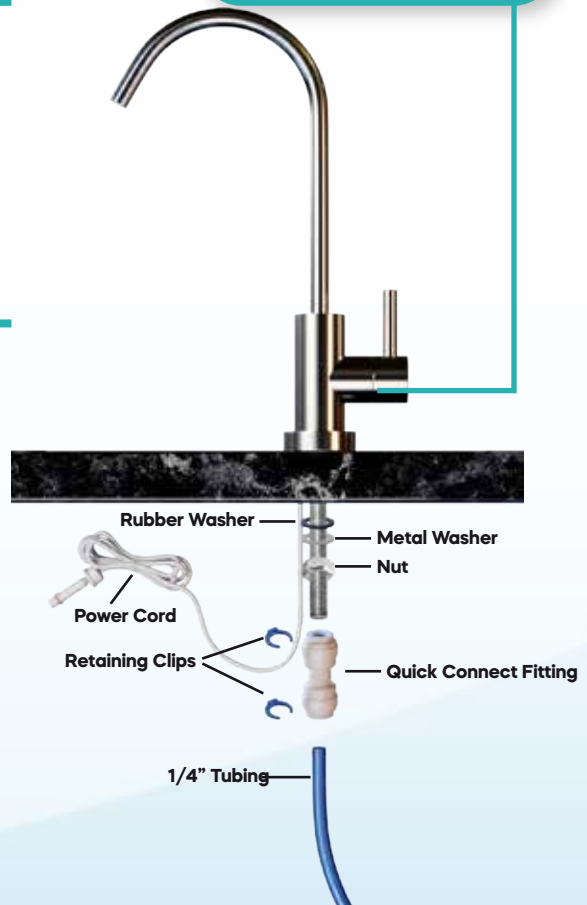
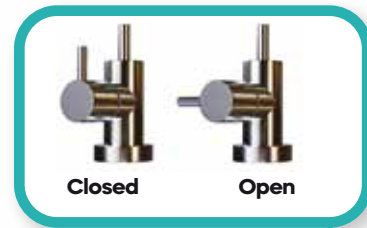

System Installation

Filter Installation

1. Place your reverse osmosis system under your sink in a location that's easily accessible.

2. Insert each filter into its corresponding placement in the reverse osmosis system and rotate clockwise to lock in position. Gently pull on the filter to ensure the filter is locked in place.

NOTICE: If your system comes with the alkaline or UV filter you may skip this page



For alkaline system proceed to page 13

For UV system proceed to page 14

For alkaline and UV system proceed to page 16

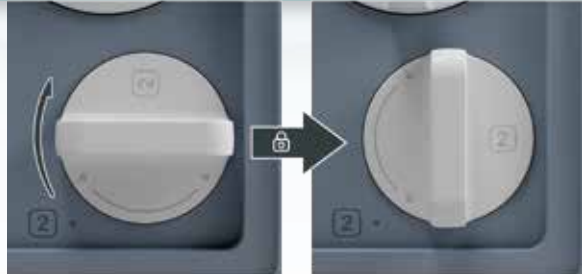

WARNING: Double check that filters are properly inserted. Check that the lock icon is aligned on the system and filter.

System Connections

1. Connect the 3/8" tubing coming from the leak detector into the IN connection on the back of the reverse osmosis system. Secure the tubing in place with a retaining clip.

2. Connect the 1/4" tubing coming from the drain saddle into the DRAIN connection on the back of the reverse osmosis system. Secure the tubing in place with a retaining clip.

3. Connect the 1/4" tubing coming from the faucet into the OUT connection on the back of the reverse osmosis system. Secure the tubing in place with a retaining clip.

4. Plug the faucet power cord into the FAUCET connection on the back of the reverse osmosis system.



Notice: Do not plug reverse osmosis system into wall outlet yet



Alkaline System Installation

Mounting

1. Hold the filter in position under the sink and space the two brackets 4–5 inches apart. Mark the screw holes with a pencil, then drive the included screws through the center of each mounting clip. On harder surfaces, drill a small pilot hole first.
2. Once secured, snap the filter down into both clips until it locks in place.



Alkaline System Connections

1. Connect the 3/8" tubing coming from the leak detector into the INPUT connection on the back of the reverse osmosis system. Secure the tubing in place with a retaining clip.
2. Connect the 1/4" tubing coming from the drain saddle into the DRAIN connection on the back of the reverse osmosis system. Secure the tubing in place with a retaining clip.
3. Connect the blue 1/4" tubing to the PURE water connection on the back of the reverse osmosis system. Connect the other end to either end of the alkaline filter. Secure both connections with a retaining clip.
4. Connect the blue 1/4" tubing coming from your faucet to the remaining open end of the alkaline filter. Secure with a retaining clip.
5. Lastly connect the cord coming from your faucet to the connection on the back of the system labeled FAUCET.



⚠ Notice: Do not plug reverse osmosis system into wall outlet yet



UV System Installation

Mounting

There are two mounting options for your UV filter. Option one is a adhesive pad. This is the easiest option but will be less secure. Option two is a hard mount that is more secure and uses screws to attach to the inside of your cabinet.

Adhesive

1. Select the location you want to install your UV Filter. This should be atleast 8 inches above the bottom of the cabinet.
2. Peel off the backing of the adhesive pad.
3. Firmly press the adhesive pad against the cabinet wall.
4. Peel off the front cover of the adhesive pad. Press the mounting plate firmly against the pad to secure it.
5. Hang the UV water filter on the mounting plate studs.

Adhesive Mount

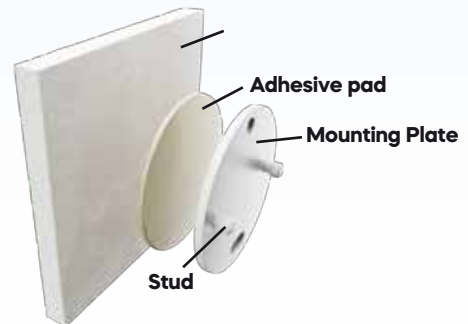

Hard Mount

1. Select the location you want to install your UV Filter. This should be atleast 8 inches above the bottom of the cabinet.
2. Secure the mounting plate directly to the cabinet wall using the supplied screws
3. Hang the UV water filter on the mounting plate studs.

Hard Mount

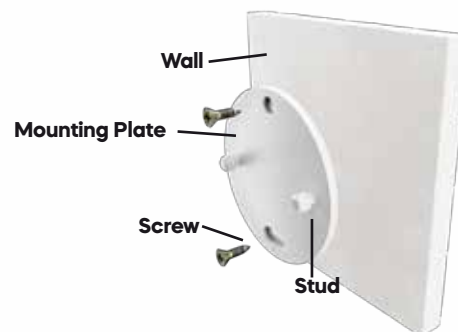

Hanging

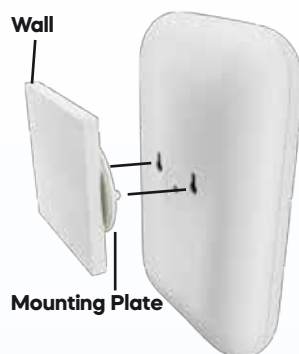

NOTE:
Improperly cut tubing may cause a leak



NOTE:
Always check each connection to make sure its secure

UV System Connections

1. Connect the 3/8" tubing coming from the leak detector into the INPUT connection on the back of the reverse osmosis system. Secure the tubing in place with a retaining clip.
2. Connect the 1/4" tubing coming from the drain saddle into the DRAIN connection on the back of the reverse osmosis system. Secure the tubing in place with a retaining clip.
3. Connect the 1/4" tubing to the PURE water connection on the back of the reverse osmosis system. Connect the other end of the 1/4" tubing to the IN connection of the UV Filter. Secure the tubing in place with a retaining clip
4. Connect the 1/4" tubing to the OUT connection on the UV filter. Connect the other end of the 1/4" tubing to the reverse osmosis faucet. Secure the tubing in place with a retaining clip.
5. Connect the power cord to your UV filter and plug into wall outlet.
6. Plug the faucet power cord into the FAUCET connection on the back of the reverse osmosis system.



! Notice: Do not plug reverse osmosis system into wall outlet yet



NOTE:
Improperly cut tubing may cause a leak



NOTE:
Always check each connection to make sure its secure

UV & Alkaline System Installation

Alkaline Filter Mounting

1. Hold the filter in position under the sink and space the two brackets 4–5 inches apart. Mark the screw holes with a pencil, then drive the included screws through the center of each mounting clip. On harder surfaces, drill a small pilot hole first.
2. Once secured, snap the filter down into both clips until it locks in place.



UV Filter Mounting

There are two mounting options for your UV filter. Option one is an adhesive pad. This is the easiest option but will be less secure. Option two is a hard mount that is more secure and uses screws to attach to the inside of your cabinet.

Adhesive

1. Select the location you want to install your UV Filter. This should be at least 8 inches above the bottom of the cabinet.
2. Peel off the backing of the adhesive pad.
3. Firmly press the adhesive pad against the cabinet wall.
4. Peel off the front cover of the adhesive pad. Press the mounting plate firmly against the pad to secure it.
5. Hang the UV water filter on the mounting plate studs.

Adhesive Mount

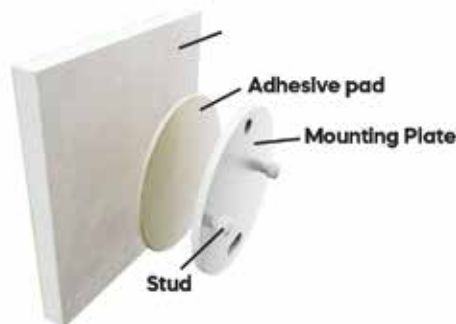

Hard Mount

1. Select the location you want to install your UV Filter. This should be at least 8 inches above the bottom of the cabinet.
2. Secure the mounting plate directly to the cabinet wall using the supplied screws.
3. Hang the UV water filter on the mounting plate studs.

Hard Mount

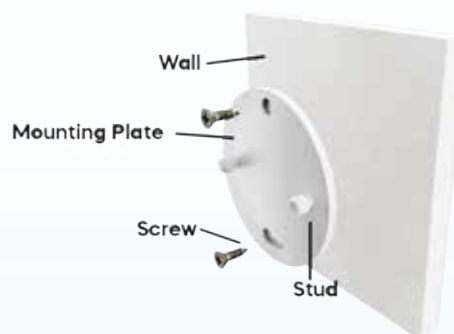

Hanging

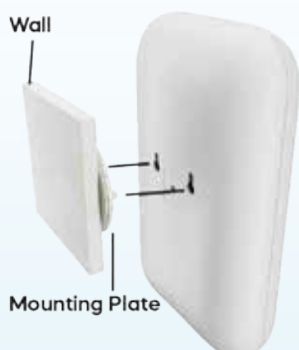

Alkaline & UV System Connections

1. Connect the 3/8" tubing coming from the leak detector into the INPUT connection on the back of the reverse osmosis system. Secure the tubing in place with a retaining clip.
2. Connect 1/4" tubing coming from the drain saddle into the DRAIN connection on the back of the reverse osmosis system. Secure the tubing in place with a retaining clip.
3. Connect the blue 1/4" tubing to the PURE water connection on the back of the reverse osmosis system. Connect the other end to either end of the alkaline filter. Secure both connections with a retaining clip.
4. Connect the blue 1/4" tubing to the other end of the alkaline filter. Connect the other end of the 1/4" tubing to the IN connection of the UV filter. Secure both connections with a retaining clip.
5. Connect the 1/4" tubing to the OUT connection on the UV filter. Connect the other end of the 1/4" tubing to the reverse osmosis faucet. Secure the tubing in place with a retaining clip.
6. Connect the power cord to your UV filter and plug into wall outlet.
7. Plug the faucet power cord into the FAUCET connection on the back of the reverse osmosis system.



Notice: Do not plug reverse osmosis system into wall outlet yet



System Startup



Do not start system without checking each connection is fully inserted into the quick connect fitting

NOTE: DO NOT DRINK ANY WATER UNTIL COMPLETING THE FLUSHING PROCESS BELOW.

1. Physically check each connection is fully inserted into it's fitting and has a retaining clip installed.
2. Slowly open the feed water valve. Wait 1 minute and check for leaks at every connection. If there are any leaks, close the feed water adapter and open the reverse osmosis faucet to relieve pressure from the system. Remove the leaking connection and reinsert the tubing. If this does not resolve the issue contact customer service.
3. Connect the power supply to the power inlet on the back of the reverse osmosis system then connect the power supply to the wall outlet.
4. Hold down the power button on the front of the system until the light next to the icon turns solid.

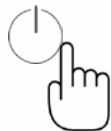

5. Now we will begin to flush the system. Open the faucet and allow the water to run for 30 minutes. This will flush the new filters of any loose filter media. It's normal for your water to have a slight gray tint during this process and will go away.



IMPORTANT: Check for leaks daily during the first two weeks after installation.



NOTE: Your water may have a slightly milky or cloudy color during the first week of use. This is caused by tiny air bubbles in the water and will go away with use.



NOTE: If your system has an alkaline filter your water's TDS will register higher. For accurate testing, testing water that has not been processed by the alkaline filter.

System Functions

System Lights

1	<input type="radio"/> Off - Filter Good
2	<input type="radio"/> Flashing White - Replace Soon
3	<input type="radio"/> Solid White - Replace Now
	<input type="radio"/> Off - No Power <input type="radio"/> Solid White - On <input type="radio"/> Flashing White - Standby Mode

Faucet Lights

	<input type="radio"/> Solid Blue - Filter Good <input type="radio"/> Flashing Blue - Rinsing In Progress
	<input type="radio"/> Flashing Orange - Replace Soon <input type="radio"/> Solid Orange - Replace Now

Error Indicator Lights

<input type="radio"/> Off - No Error <input type="radio"/> Solid White - 2 Hour Continuous Protection <input type="radio"/> Flashing White - Water Shortage	<p>Unplug power supply and reconnect to reset error indicator</p> <p>Unplug power supply. Check feed water adapter is fully open and water flows regularly from your kitchen faucet. Reconnect power supply to reset error indicator.</p>
---	---

Filter Changes

Scan Me!



**WANT YOUR FILTERS DELIVERED AUTOMATICALLY?
JOIN THE FILTER CLUB AND GET YOUR FILTERS
AT A DISCOUNT.**

1. Close your feed water adapter to stop the flow of water to your system.
2. Unplug the system power supply from your wall outlet. If you have a UV filter disconnect the power supply from your wall outlet.
3. Rotate the filter counterclockwise to unlock the it and then pull the filter out from the system.



4. Insert your new replacement filter into the system and turn it clockwise to lock it into place. Rotate the filter so that the lock icon on the filter is aligned with the lock icon on the system.



5. With your new filters installed, open the feed water adapter to allow water into the system.
6. Plug your power supply into your wall outlet as well as your UV filter if your system is equipped with one.
7. Now reset the filter reminder on the system. Hold the button for the corresponding filter number on the system that you've replaced for 3 seconds until the light flashes. The icon light will now turn off indicating the filter has been reset successfully.

1

2

3



8. Now that your filter has been replaced, you must flush your system again. Open the faucet and allow the water to run for 30 minutes. Once completed, your system is ready for use.

Troubleshooting

Problem	Causes	Solution
Milky colored water Air bubbles in water	<ul style="list-style-type: none"> • Air in the system 	<ul style="list-style-type: none"> • Air in the system is normal with initial installation and startup. This will clear up within 1 to 2 weeks.
Water taste or an offensive smell	<ul style="list-style-type: none"> • Drain line clogged • Inline post carbon filter is depleted 	<ul style="list-style-type: none"> • Check for clog in drain line and clear. • Replace inline carbon filter. • Replace RO membrane.
System does not turn on	<ul style="list-style-type: none"> • no power to system • Power supply failure 	<ul style="list-style-type: none"> • Ensure outlet is not on a switch • Plug power supply in different outlet • Contact customer support
Leaks	<ul style="list-style-type: none"> • Tubing not fully inserted • Twisted/damaged O-ring • Misalignment of hole in drain saddle 	<ul style="list-style-type: none"> • Reinsert tubing • Replace the O-ring. • Realign drain saddle.
No water	<ul style="list-style-type: none"> • Check leak stop valve • Check feed water adapter valve 	<ul style="list-style-type: none"> • Replace leak stop valve. • Check water flows from feed water adapter. If no water comes through,
Loud or noisy system	<ul style="list-style-type: none"> • Objects on top of system • normal sound of pump 	<ul style="list-style-type: none"> • Remove object. This can cause vibrating noise • The pump produces a low sound when operating
Faucet light not turning on	<ul style="list-style-type: none"> • No power to faucet • Damaged faucet 	<ul style="list-style-type: none"> • Reconnect faucet plug into system • Unplug system power supply, wait 10 seconds and plug back in • Contact customer support
Water TDS is testing high	<ul style="list-style-type: none"> • System has sat for extended time • RO membrane has expired • High TDS source water 	<ul style="list-style-type: none"> • Open the faucet and let the system run for 10 minutes • Replace RO membrane • Test source water TDS. The pure water should test 5-10% of your water TDS

Limited Product Warranty

SCOPE

NU Aqua Systems takes pride in selling the highest quality reverse osmosis system ("Product") on the market. As such, NU Aqua Systems expressly warrants to the original purchaser that, for a period of one (1) years from the date of purchase, the Product will be reasonably free of defects in materials and workmanship. Within that one (1) year period from the original purchase, NU Aqua Systems will, at its option, repair or replace the Product without charge, or refund the cost of the Product, if the Product fails or does not perform as warranted solely due to a manufacturing defect within the warranty period, subject to the limitations and exclusions set forth in this Limited Product Warranty. This Limited Product Warranty only applies when the Product is used, stored, handled, fabricated and/or installed in the manner recommended by NU Aqua Systems in the Installation Instruction & Owner's Manual ("Manual").

REPAIR OR REPLACEMENT

Repair or replacement during this one (1) year warranty does not include labor charges, freight charges or any other local charges from third parties other than NU Aqua Systems, unless NU Aqua Systems expressly approves such charges in writing. During the entire one (1) year warranty, NU Aqua Systems's obligation to repair or replace shall further be limited to repair or replacement with the styles, models, products, colors, etc. of the Product that are available at the time of the repair or replacement, and shall be limited to the repair or replacement of only the specific Product that fails due to a manufacturing defect. Any repaired or replaced product shall also remain subject to the original one (1) year warranty from the date of the original purchase, and any repair or replacement shall not extend the original warranty period in any manner or start a new warranty period.

CONDITIONS OF VALIDITY OF THIS LIMITED PRODUCT WARRANTY

Even though the Product has extremely high endurance for operating conditions such as pH, maximum TDS, temperature, and optimum water pressure,

THIS LIMITED PRODUCT WARRANTY SHALL ONLY BE VALID IF:

1. The replaceable filters and membrane are changed and maintained on a regular basis as directed in the Manual. Moreover, depending on local water input water quality, regular maintenance may need to be increased.
2. The Product is operated within the confines of the following feed water conditions:
 - **Water Pressure: 14.5 - 58 PSI**
 - **PH Range:2-11 Max. TDS: 1000 PPM Water Temperature: 41°-100.4° F SDI: 5**

Any information or suggestion by NU Aqua Systems with respect to the Product concerning applications, specifications or compliance with codes and standards is provided solely for your convenient reference and is made without any representation as to accuracy or suitability. You must verify and test the suitability of any information with respect to the Product for your specific application.

NON-COVERED DEFECTS

THIS LIMITED PRODUCT WARRANTY DOES NOT COVER DEFECTS CAUSED BY:

1. Improper storage, installation, maintenance, handling, use and/or alterations of the Product, including, but not limited to, noncompliance with the installation, maintenance and standard operation conditions stated in the Manual and this Limited Product Warranty.
2. Unreasonable use, unintended use, or misuse of the Product for something other than its intended purpose as a reverse osmosis system.
3. Use of replacement parts, filters, membranes or other accessories that are not sold or manufactured by NU Aqua Systems for use with this particular Product.
4. Damage not resulting from manufacturing defects that occur while the Product is in the original purchaser's possession.
5. Installation of the Product with known or visible manufacturing defects at the time of installation.
6. Damage caused by freezing, flood, fire or Act of God.

Limited Product Warranty

THIS LIMITED PRODUCT WARRANTY SHALL BE VOID IF:

1. The Product is not operated in compliance with normal municipal water conditions for which the particular model of this Product is intended.
2. The person seeking to invoke the warranty is not the original purchaser. That is, this Limited Product Warranty only extends to original purchasers.
3. The Product is purchased used. That is, this Limited Product Warranty only covers new products.
4. The Product is purchased from someone other than NU Aqua Systems or one of NU Aqua Systems authorized dealers. This is because, unless the Product was sold by NU Aqua Systems or one of its authorized dealers, NU Aqua Systems cannot verify or guarantee the integrity or authenticity of the Product.

GENERAL CONDITIONS

The warranties set forth herein are the only warranties made by NU Aqua Systems in connection with the product. NU Aqua Systems cannot and does not make any implied or express warranties with respect to the product, and disclaims all other warranties, including, but not limited to, any warranty of merchantability or fitness for a particular purpose. Products sold by NU Aqua Systems are sold only to the specifications specifically set forth by NU Aqua Systems in writing. Other than the limited product warranty set forth herein, NU Aqua Systems makes no other warranties, express or implied. NU Aqua Systems's sole obligation under this warranty shall be repair or replacement of a non-conforming product or parts of the product, or at the option of NU Aqua Systems, return of the product and a refund of the purchase price. Buyer assumes all risk whatsoever as to the result of the use of the product purchased, whether used singularly or in combination with any other products or substances.

No claim by the buyer/owner of any kind, including claims for indemnification, shall be greater in amount than the purchase price of the products in respect to which damages are claimed. In no event shall NU Aqua Systems be liable to buyer/owner in tort, contract or otherwise, for any special, indirect, incidental, consequential, reliance, statutory, special, punitive or exemplary damages, including, but not limited to, lost profits, loss of use, loss of time, inconvenience, damage to goodwill or reputation, or loss of data, even if advised of the possibility of such damages or such damages could have been reasonably foreseen, in connection with, arising out of, or as a result of, the sale, delivery, servicing, use or loss of use of the products sold hereunder, or for any liability of buyer to any third party with respect thereto.

In case some states do not allow the exclusion or limitation of incidental or consequential damages, you may choose to return the Product. If you choose to keep it, you insist this exclusion still applies to you.

OBTAINING WARRANTY COVERAGE OR GENERAL INQUIRIES

If coverage is available, you may obtain coverage under this Limited Product Warranty by providing NU Aqua Systems with proof of original purchase, and that you are the original purchaser. For service under this Limited Product Warranty, you must notify NU Aqua Systems by phone at 1-888-621-0460, by email at support@nuaquasystems.com. In making the claim, please provide your name, address, phone number, a description of the product involved, and an explanation of the defect.

LIMITED LIFETIME* WARRANTY

NU Aqua Systems provides a Limited Lifetime* Warranty when original purchaser enrolls in the NU Aqua Systems Filter Club Subscription service and changes the Product's filters at the recommended cadence with genuine NU Aqua System replacement filters. The lifetime warranty does not cover normal wear and tear parts such as O-Rings, fittings, tubing, filters, faucets and teflon tape.

*The term Lifetime refers to the lifetime of the Product. This does not mean the purchaser's lifetime, but rather the expected lifetime of the Product. The expected lifetime of the Product is 10 Years. However, at NU Aqua Systems discretion, we may cover warranty claims in excess of the Product expected lifetime.